



# IMPORTANT SAFETY PRECAUTIONS

## ⚠ CAUTION

To Avoid the Risk of Electrical Shock Personal Injury, or Death:

Your range must be properly grounded and installed by a qualified installer. It is the personal responsibility and obligation of the customer to contact a qualified electrician/installer and have the unit connected to a properly grounded circuit in accordance with the National Electric Code.

## ⚠ WARNING

This product contains or produces a chemical or chemicals which may cause serious illness or death and which are known to the State of California to cause cancer, birth defects or other reproductive harm.

## ⚠ CAUTION

To Avoid the Risk of Personal Injury use this appliance only for its intended purpose as described in this manual.

## ⚠ CAUTION

Do not store items of interest to children in cabinets above a range or on the backguard of a range - children climbing on the range to reach items could be seriously injured.

**WARNING:** To reduce the risk of the appliance tipping, it must be secured by a properly installed anti-tipping device. To make sure the device has been installed properly, remove the drawer and look under the range with a flashlight.

## ⚠ WARNING



- ALL RANGES CAN TIP
- INJURY TO PERSONS COULD RESULT
- INSTALL ANTI-TIP DEVICE PACKED WITH RANGE
- SEE INSTALLATION INSTRUCTIONS

## ⚠ CAUTION

Do not touch surface or oven heating elements. Even though they may be dark in color areas near the surface units and interior portions of the oven remain hot enough to cause burns. During and after use do not touch, or let clothing or other flammable material contact heating elements, areas near heating elements or the interior portions of the oven.

Other areas of the oven and cooktop may also become hot enough to cause burns. Among these surfaces are oven vent openings, surfaces near the oven door, oven window, oven racks and surfaces facing the cooktop.

# IMPORTANT SAFETY INSTRUCTIONS

## READ BEFORE OPERATING YOUR RANGE

1. Be sure your appliance is properly installed and grounded by a qualified technician.
2. Never use your appliance for warming or heating the room.
3. Do not leave children alone or unattended while the range is in operation. Children should not be left alone or unattended in an area where the appliance is in use. They should never be allowed to sit or stand on any part of the appliance.
4. **Wear Proper Apparel** - Loose-fitting or hanging garments should never be worn while using the appliance.
5. **User Servicing** - Do not repair or replace any part of the range unless specifically recommended in this manual. All other servicing should be referred to a qualified technician.
6. **Storage in or on Appliance** - Flammable materials should not be stored in an oven or near surface units.
7. **Do Not Use Water on Grease Fires** - Smother fire or flame with a non-flammable lid, or use dry chemical or foam-type extinguisher.
8. **Use Only Dry Potholders** - Moist or damp potholders on hot surfaces may result in burns from steam. Do not let pot holder touch hot heating elements. Do not use a towel or other bulky cloth.

### Surface Cooking Units

1. **Use Proper Pan Size** - This appliance is equipped with one or more surface units of different sizes. Select utensils having flat bottoms large enough to cover the surface unit heating element. The use of undersized utensils will expose a portion of the heating element to direct contact and may result in ignition of clothing. Proper relationship of utensil to burner will also improve efficiency.
2. **Never leave Surface Units Unattended at High Heat Settings** - Boilover causes smoking and greasy spillovers that may ignite.
3. **Utensil Handles Should Be Turned Inward and Not extend Over Adjacent Surface Units** - To reduce the risk of burns, ignition of flammable materials, and spillage due to unintentional contact with the utensil, the handle of a utensil should be positioned so that it is turned inward, and does not extend over adjacent surface units.
4. **Glazed Cooking Utensils** - Only certain types of glass, glass/ceramic, ceramic, earthenware, or other glazed utensils are suitable for range-top service without breaking due to the sudden change in temperature.

### Ovens

1. **Use Care When Opening Door** - Let hot air or steam escape before removing or replacing food.
2. **Do Not Heat Unopened Food Containers** - Build up of pressure may cause container to burst and result in an injury.
3. **Keep Oven Vent Ducts Unobstructed.**
4. **Placement of Oven Racks** - Always place oven racks in desired location while oven is cool. If rack must be moved while oven is hot, do not let potholder contact hot heating element in oven.

# IMPORTANT SAFETY INSTRUCTIONS

## Self-Cleaning Oven

1. **Do Not Clean Door Gasket** - The door gasket is essential for a good seal. Care should be taken not to rub, damage, or move the gasket.
2. **Do Not Use Oven Cleaners** - No commercial oven cleaner or oven liner protective coating of any kind should be used in or around any part of the oven.
3. **Clean Only Parts Listed In This Manual.**
4. **Before Self-Cleaning the Oven** - Remove broiler pan, other utensils, and oven racks.

## Conventional Coil Cooking Surfaces

1. **Clean Cooktop with Caution** - If a wet sponge or cloth is used to wipe spills off a hot cooking area, be careful to avoid steam burns. Some cleaners can produce noxious fumes if applied to a hot surface.
2. **Make Sure the Burner Bowls or Reflector Pans Are in Place.** If they are not in place during cooking you may subject wiring or components underneath to damage.
3. Do not use aluminum foil to line surface unit burner bows or oven bottoms, except as suggested in the Use and Care Manual. Improper installation of these liners may result in a risk of electric shock, or fire.
4. **Do Not Soak Removable Coil Heating Elements.** The elements should not be immersed in water.

## Ventilating Hoods

1. **Clean Ventilating Hoods Frequently** - Grease should not be allowed to accumulate on hood or filter.
2. When flaming foods under the hood, turn the fan off. The fan, if operating may spread the flame.

## IN CASE OF FIRE

Fires can occur as a result of over cooking or excessive grease. Though a fire is unlikely, if one occurs proceed as follows:

### Surface Element Fire

1. **DO NOT turn on a range vent hood.** The flames could be drawn into the hood where more damage could result.
2. Smother the fire with a non-flammable lid or baking soda, or use a Class "ABC" or "BC" extinguisher. Not water. Not salt. Not flour.
3. As soon as it is safe to do so, turn the surface element controls to "OFF."

### Oven Fires

1. If you see smoke from your oven, **do not open the door.**
2. Turn the oven control to "OFF"
3. As an added precaution, turn off the power at the main circuit breaker or fuse box.
4. Turn on the range vent hood or exhaust fan, if you have one, to remove smoke.
5. Allow food or grease to burn itself out in the oven.

**OF COURSE, IF SMOKE AND FIRE PERSIST, CALL THE FIRE DEPARTMENT.**

If there is any damage to components, call your repair service before reusing the range or cooktop again.

- Do not cook food directly on the cooktop surface; always use cookware.
- Do not mix household cleaning products. Chemical mixtures may interact, with objectionable or even hazardous results.
- Do not put plastic items on warm cooking areas. They will stick and melt.
- Do not slide rough metal objects across rangetop surface. Scratching or metal marking can result.
- Do not use cookware with rough bottoms. They may scratch the surface of the element. Glass and glass-ceramic cookware can be used on coil elements.
- Do not use a sponge or dishcloth to clean the rangetop. A film of soil-laden detergent water may collect on the rangetop. If this should happen, Amana ASAP™ Cleaner-Conditioner will remove the stain.
- Do not leave fat heating unless you remain nearby. Fats can ignite if overheated by spilling onto hot surfaces.
- Do not allow pots to boil dry on high settings as this can cause damage to the cooking surface and the pan.
- Do not use the rangetop surface as a cutting board.

---

## CONGRATULATIONS!

You have purchased an appliance that when operated correctly, should give you years of top quality performance. Your range was designed with safety in mind to give you cooking convenience and enjoyment. Read this book carefully before operating your new range and keep it nearby to refer to when necessary.

For future reference, record basic range information found on your range serial plate and retain a copy of your sales receipt for proof of purchase. The product serial plate is located on the oven frame below the oven door. (Open the oven drawer to see the serial plate.)

1. Model Number \_\_\_\_\_ Serial Number \_\_\_\_\_  
Color \_\_\_\_\_ Manufacturing No. \_\_\_\_\_

2. Dealer's Name \_\_\_\_\_ Phone Number \_\_\_\_\_  
Address \_\_\_\_\_

3. Date Purchased \_\_\_\_\_ Date Installed \_\_\_\_\_

4. Installer's Name \_\_\_\_\_ Phone \_\_\_\_\_  
Address \_\_\_\_\_

5. Dealer Recommended Service Center \_\_\_\_\_  
Phone \_\_\_\_\_  
Address \_\_\_\_\_

# RANGE FEATURES

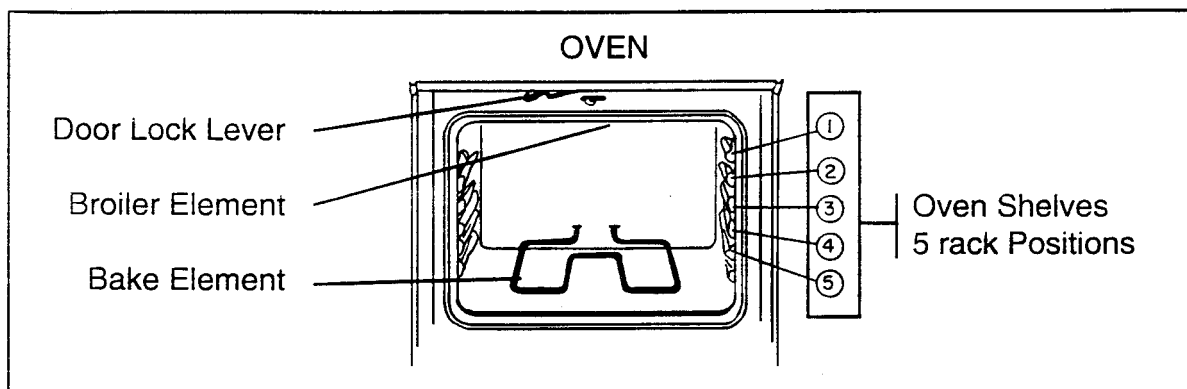

## CONTROL KNOBS

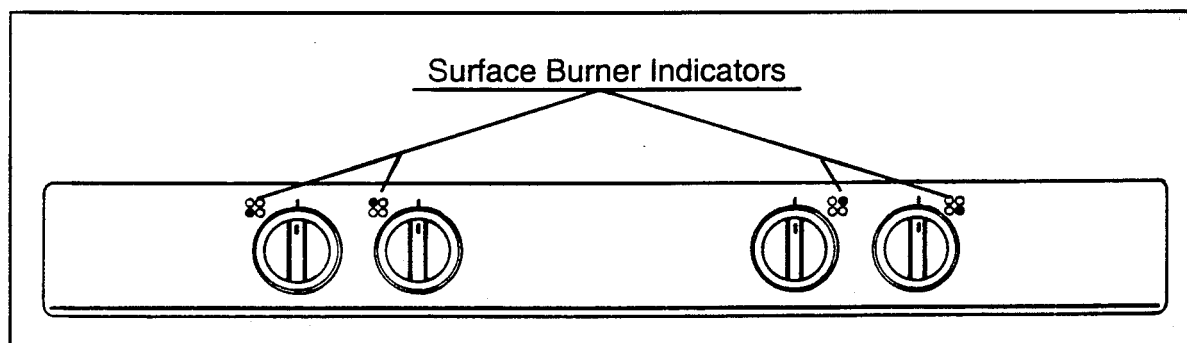

## CLOCK AND OVEN CONTROLS

### SETTING THE CLOCK

1. Push in the set knob.
2. Rotate the knob to the desired time of day.

### SETTING THE MINUTE TIMER

1. Rotate the set knob to the desired time.
2. Buzzer will sound when time has elapsed.

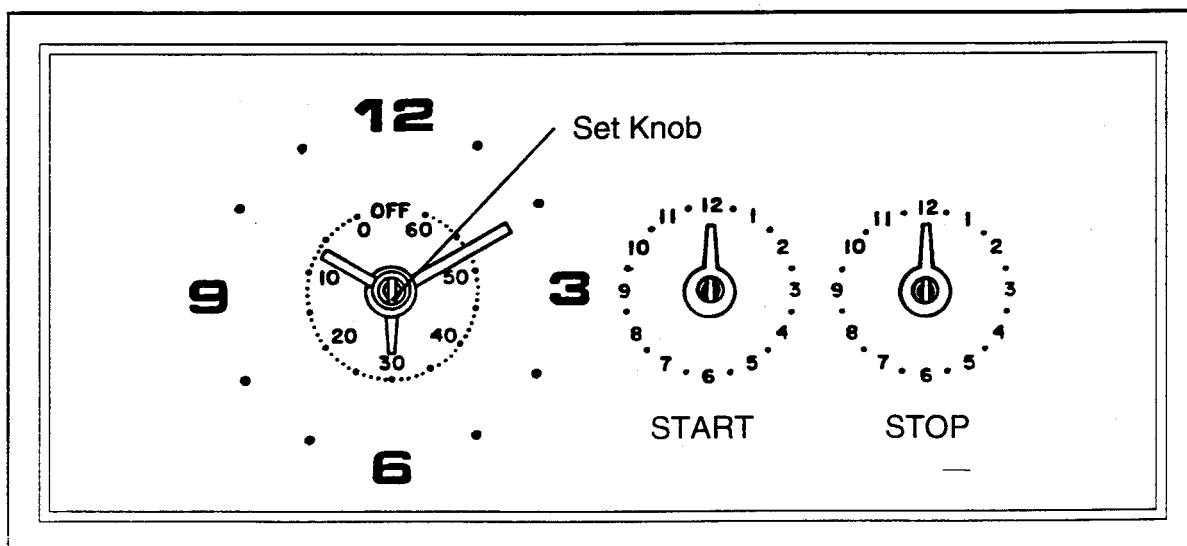

# HOW TO USE THE COOKTOP

## 1. USE THE PROPER PAN SIZE

Select utensils that have flat bottoms large enough to cover the element. Using undersized utensils will expose a portion of the burner to direct contact with clothing or spillovers. A utensil that is correctly sized will also improve efficiency.

## 2. NEVER LEAVE SURFACE UNITS UNATTENDED

At high heat settings boilovers can cause smoking or fire.

## 3. GLAZED COOKING UTENSILS

Only certain types of glass, glass/ceramic, earthenware or other glazed utensils are suitable for use with range top. Due to the sudden change in temperature some glazed utensils may break.

## 4. UTENSIL HANDLES SHOULD BE TURNED INWARD

A handle that extends away from the range could be unintentionally tipped.

## COOKING UTENSILS

**GLASS-CERAMIC** cookware responds slowly to temperature changes. It responds best to long and slow heating of liquids.

**ALUMINUM** Responds quickly to temperature changes. It responds best for frying, braising and roasting.

**CAST IRON** responds slowly to temperature changes. It responds best for long low heat cooking and pan frying.

**STAINLESS STEEL** is usually combined with another metal such as copper, to better respond to temperature changes. It may be used for soups, sauces, vegetables and general cooking.

**COPPER, TIN-LINED** cookware responds quickly to temperature changes. It is excellent for gourmet cooking, wine sauces and egg dishes.

**ENAMELWARE** is stain resistant porcelain over metal. The cooking time can be determined by the base metal, however, lower temperatures are usually recommended.

- FLAT BOTTOMS AND STRAIGHT SIDES
- HANDLE WEIGHT THAT DOES NOT TILT THE PAN
- MATCH THE PAN SIZE TO THE BURNER SIZE

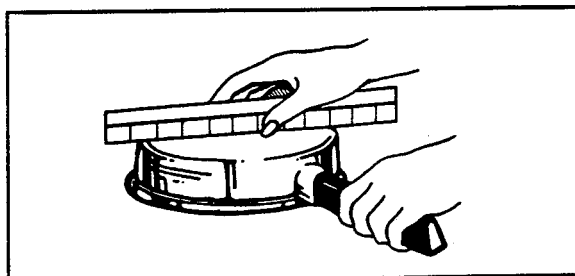

### **CAUTION**

To avoid damage to the cooktop, do not use any cooking utensil that overhangs the surface element by more than one inch.

# OPERATING THE COOKTOP

## SETTING THE SURFACE CONTROLS

### To Use:

Push In and Turn the control to the desired setting. The surface unit indicator will light.

### When finished:

Turn all controls to "Off". The surface unit indicator lights will turn off.

## COOKING ON THE SURFACE OF YOUR RANGE

Cooking on the surface of your electric range is done by conduction. When the unit is turned on, an electric current heats the element. The element will heat the pan when they are in proper contact. Your range is equipped with reflector pans. The element rests on the reflector pan. The reflector pan reflects heat to the bottom of your cooking utensil and catches spillovers.

The controls for the surface of the range are located on the backguard. You must Push In and Turn the controls. They can be adjusted in either direction. The illustration on the top right of each knob will show the burner it will operate.

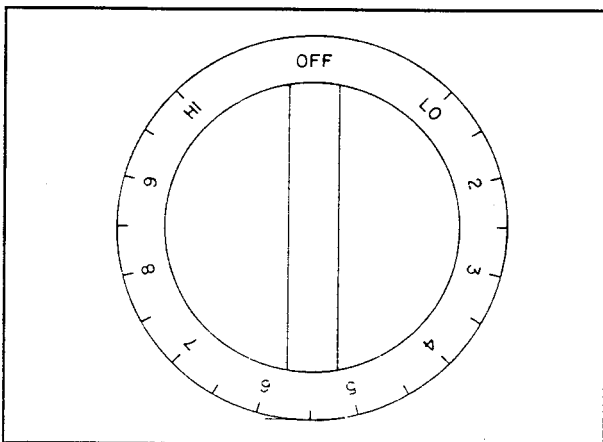

## KNOB SETTINGS

Each dial can be set to any required cooking temperature. In addition, there are distinct "click" features for "HI", "LO", and "OFF".

The element will cycle on and off to maintain the desired temperature. The temperature you select should be based on the amount of food and the type of utensil. The following guide will help you prepare the average family meal.

"LO" should be used for food that is prepared at less than boiling temperatures. It can also be used to keep food and beverages at serving temperatures.

"2" through "4" can be used to maintain boiling of larger amounts of food, low temperature frying and to maintain correct pressure in a pressure cooker. "5" through "6" should be used to maintain boiling of larger amounts of food, low temperature frying and to maintain correct pressure in a pressure cooker.

"7" through "9" can be used to fry meat poultry or to maintain deep-fat frying temperatures.

"HI" should be used to bring food to boiling temperatures.

If electric cooking is new to you, some of the processes will differ from those you experienced with a gas range. Heat up and cool down times for your elements will be different depending on the chosen setting. Remember the element will retain heat after it has been turned off. This heat can sometimes help finish cooking the food.

# USING THE OVEN

## OVEN RACKS

Both oven racks may be used for conventional baking and roasting. They will pull to a "stop" position without tipping.

To Remove The Racks:

1. Pull the rack forward to the first "stop" position.
2. Raise the forward edge of the rack (as shown below) and pull it past the second "stop".

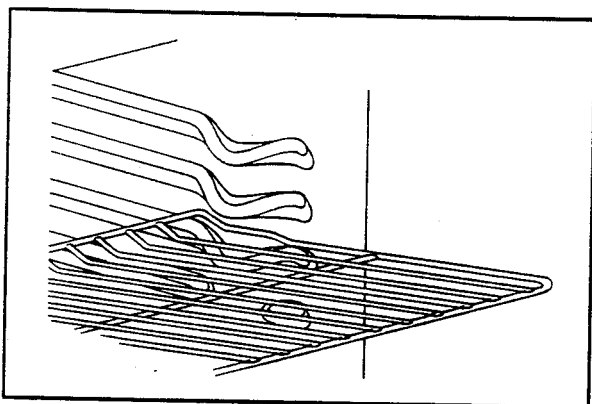

## PAN PLACEMENT

When placing baking pans and cookie sheets, the pans should be kept a distance of two inches from the side and rear walls. If roasting or baking pans are placed on different racks, they should be staggered so that one is not located directly under another. This will assure good distribution of heat and will allow food in both pans to be thoroughly cooked.

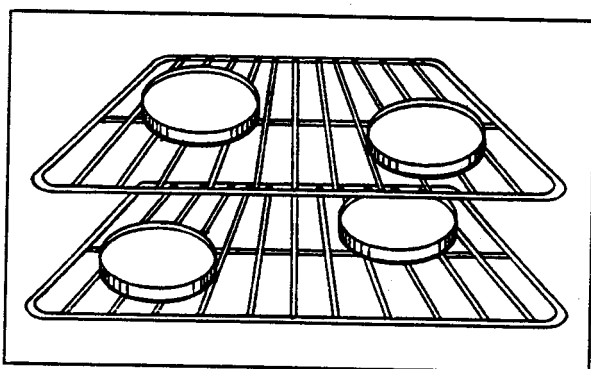

## OVEN TIPS:

- Use care when you open the oven door. Let any hot air or steam escape before removing or replacing food.
- Avoid frequent door openings. Use the oven light to view the food.
- For possible pie or casserole overflow, cut a piece of aluminum foil slightly larger than the utensil, and turn up the edges.

## RACK ARRANGEMENTS

The oven provides five different rack positions. The racks should be arranged before preparing foods or turning "ON" the oven. Refer to the section in this manual on BROILING to identify each rack position.

### **⚠ CAUTION**

**To Avoid a Possible Fire: Never cover the oven racks, oven bottom or oven elements with aluminum foil. Covering the oven racks will seriously affect baking results**

## SETTING THE OVEN TO BAKE

1. Adjust the oven racks to the desired levels.
2. Place the food in the oven.
3. Turn the Thermostat Knob to the desired temperature.
4. Turn the Selector Knob to "BAKE".

**When Finished:**

1. Turn all controls to "OFF".

# AUTOMATIC BAKING AND ROASTING

## SETTING THE OVEN TO START AUTOMATICALLY

1. Place the food in the oven.
2. Check the clock and make sure it is set at the correct time of day.
3. Set the controls as follows:
  - Push in and turn the start knob to the time you wish the food to start cooking.
  - Turn the oven selector knob to "TIMED BAKE"
  - Push in and turn the oven temperature control knob to the desired setting.

### WHAT TO EXPECT:

When the time of day reaches the time set on the START knob the oven will automatically start. The oven will continue to cook until it is turned off manually.

WHEN YOU FINISH COOKING TURN ALL CONTROLS TO OFF.

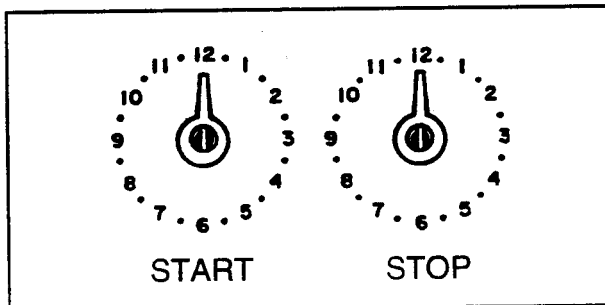

## SETTING THE OVEN TO STOP AUTOMATICALLY

1. Place the food in the oven.
2. Check the clock and make sure it is set at the correct time of day.
3. Set the selector and temperature knobs to the desired settings.
4. Set the "STOP" knob to the desired stopping time.

### WHAT TO EXPECT:

The oven will begin to cook within 60 seconds after you have finished setting it. When the time of day reaches the time set on the Stop Knob the oven will automatically Stop. WHEN YOU FINISH COOKING, TURN ALL CONTROLS TO OFF.

## SETTING THE OVEN TO START & STOP AUTOMATICALLY

1. Place the food in the oven.
2. Check the clock and make sure it is set at the correct time of day.
3. Set the controls as follows:
  - Turn the oven selector knob to "TIMED BAKE".
  - Push in and turn the temperature control knob to the desired setting.
  - Push in and turn the "START" knob to the desired starting time.
  - Push in and turn the "STOP" knob to the desired stopping time.

### WHAT TO EXPECT:

When the time of day reaches the time set on the Start knob, the oven will automatically start. The oven will continue to cook until the time of day reaches the time set on the Stop knob. When the time of day reaches the pre-set stop time, the Stop knob will pop out of the locked position.

WHEN YOU FINISH COOKING TURN ALL CONTROLS TO OFF.

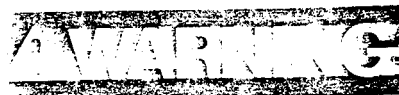
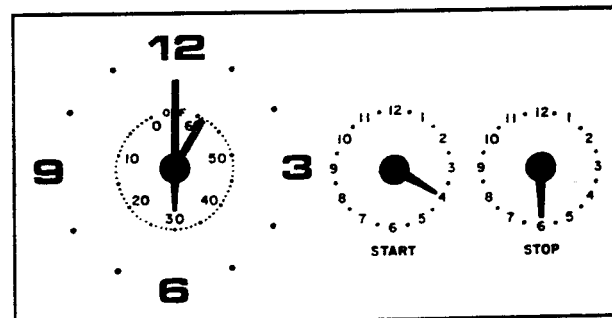

To avoid the risk of food poisoning never delay cooking meat, poultry, milk, egg or fish products more than 2 hours.

# OVEN BAKING GUIDE

Hot Oven 400° - 500°F • Moderate Oven 350° - 375° • Slow Oven 300° - 350°F

Follow this guide for time and temperature unless they are given in the recipe you are using. Baking time will vary with temperature of ingredients and size and type of utensil being used. However, if oven temperature is correct, the cooking time should not vary more than that given in the guide.

TEMPERATURE		
FOOD	DEGREES	MINUTES
<b>YEAST BREADS</b>		
Bread .....	400° .....	45-60
Rolls .....	375° .....	25-30
<b>QUICK BREADS</b>		
Baking Powder Biscuits .....	450° .....	12-15
Muffins .....	425° .....	20-25
Popovers .....	375° .....	45-60
Popovers with oven meal .....	350° .....	60-75
Nut Bread .....	400° .....	50-60
Corn Bread .....	375°-400° .....	30
<b>COOKIES</b>		
Drop .....	350°-375° .....	20-25
Rolled .....	375°-400° .....	8-12
Sliced .....	375°-400° .....	8-12
Brownies .....	350° .....	25-30
<b>PIES</b>		
Pie Shells .....	475° .....	10-15
Custard .....	400° .....	35-40
Pumpkin .....	475° .....	10-15
Apple .....	400° .....	45-60
Berry .....	425° .....	45-60
Mince .....	425° .....	35-40
<b>CAKES</b>		
8" Layer .....	375° .....	25-30
9" Layer .....	350° .....	30-35
Cup Cakes .....	375° .....	20-25
Loaf Cakes .....	350° .....	45-60
Angel Food .....	350° .....	40-50
Sponge .....	350° .....	40-50
Jelly Roll .....	425° .....	12-15
Fruit .....	250°-275° .....	2-4 Hrs.
Gingerbread .....	350° .....	30-50

# CONVENTIONAL ROASTING

For best results, a shallow pan close to the size of the meat is recommended. The broiler pan can be used if necessary.

Place the meat on a rack or grid with the fatty side up. Do not cover or add water.

Place the pan on the oven rack with the center of the meat- in the center of the oven.

Set the Oven Control to the desired temperature. Refer to the Roast Guide in this section.

## USEFUL INFORMATION

When roasting frozen meats, allow 1/3 to 1/2 more cooking time than for roasts already thawed.

After cooking is complete, allow the roast to stand 15 to 20 minutes before carving.

Rare or medium rare meats can be removed slightly before they are ready; they will continue to cook while the roast is standing to be carved.

Meats and poultry prepared in the dry "roasted" method should not be covered; nor should water be added prior to roasting.

## ROAST GUIDE

(An aid for roasting times and temperatures)

FOOD	OVEN TEMP.	MIN./ LBS.
<b>BEEF</b>		
• Roasts .....	325°	
rare .....		20-25
medium .....		26-30
well done .....		33-35
• Rolled Roasts .....	325°	
rare .....		32-36
medium .....		36-40
well done .....		43-45
<b>PORK (fresh) .....</b>		
	325°	
• Fresh Ham (whole) .....		22-28
• Loin .....		35-40
• Shoulder, Butt .....		40-45
• Shoulder, Picnic .....		35-40
<b>HAM (smoked mild cure) ...</b>		
	350°	
• Picnic Shoulder .....		30-35
FOOD	OVEN TEMP.	APPROX. COOK TIME IN HRS.
<b>CHICKEN*</b> .....		
	375°	
• 4 to 5 lbs. ....		1-1/2 to 1-3/4
• over 5 lbs. ....		1-3/4 to 2
<b>TURKEY**</b> .....		
	325°	
• 6-8 lbs. ....		3-1/2 to 4
• 8-12 lbs. ....		4 to 4-1/2
• 12-16 lbs. ....		5-1/2
• 20-22 lbs. ....		7 to 8-1/2
<b>DUCK</b> .....		
	325°	
• 3-5 lbs. ....		1-1/2 to 2
<b>GOOSE</b> .....		
	325°	
• 6-8 lbs. ....		3 to 3-1/2

\* Small chickens can also be roasted at 400° for darker browning. If so, the cooking time should be shortened.

\*\* For stuffed turkey or duck, cooking time may increase 15 to 20 minutes.

# KEEPING FOOD WARM

The Keep-Warm oven setting can be helpful in many ways.

If you wish to use the Keep-Warm feature immediately after baking at a higher temperature, turn the oven control dial to the Warm setting (see chart) and open the oven door for 10 to 15 minutes to allow excess heat to escape.

**NOTE: If you plan to keep food warm on a platter, be sure the oven has cooled after baking before placing the platters in the oven.**

**TO AVOID THE RISK OF FIRE, DO NOT USE PLASTIC PLATTERS, OR SILVER TRAYS IN THE KEEP WARM OVEN.**

To prevent moist foods such as cooked vegetables, mashed potatoes, gravy, yeast rolls, biscuits, etc. from drying out, they should be covered tightly before being placed in the oven. Aluminum foil is ideal for this.

Meat can be carved ahead of time and then kept warm. Sliced meats can be covered to prevent cut surfaces from drying. If you wish to slice rare or medium meats you can do so if you do not allow the cut surfaces to remain exposed to the air. Cut the slices as described but keep the surfaces close together.

## THAWING FROZEN FOODS

The Keep-Warm setting may be used for thawing frozen foods. Poultry should only be thawed until the giblets can be removed. Thaw cut-up poultry, fish or meat cuts just enough to separate the pieces. Ground meat should be thawed just enough to allow you to mix and form it. Once the food is thawed, cook it immediately. Do not refreeze food that has been thawed.

To thaw and freshen cooked frozen baked goods, use the Warm setting. Wrap food loosely to prevent drying but to permit the evaporation of ice crystals formed during freezing.

## KEEP-WARM OVEN CHART

BACON .....	225°
BEEF	
Rare .....	Warm
Medium .....	Warm
Well Done .....	Warm
FISH .....	
Baked or Broiled (loosely covered)	Warm
HAM .....	Warm
LAMB .....	Warm
PORK	
Fresh .....	Warm
Smoked .....	Warm
POULTRY	
Roasted .....	Warm
Fried .....	Warm
SEAFOOD	
Baked or Fried (loosely covered)	Warm
VEGETABLES	
(covered) .....	Warm
BISCUITS/MUFFINS .....	Warm
CASSEROLES .....	200°
GRAVY .....	Warm
PIZZA	
(loosely covered) .....	225°
ROLLS	
(tightly wrapped) .....	Warm
DEEP FAT FRIED FOOD .....	200°
POTATOES	
Baked .....	200°
potatoes .....	Warm
(loosely covered) .....	250°
PIES/PASTRY .....	Warm

## BAKING PROBLEMS. REASONS WHY, WHAT TO DO:

PROBLEM	REASON WHY	WHAT TO DO
Cookies, biscuits, burn on bottom	Oven preheat time too short.	Allow oven to preheat to desired temperature.
	Oven shelf overcrowded.	Select pan sizes that leave air-space on all sides of pan.
	Pan heats too fast.	Use light colored baking sheets.
Bread does not rise in oven.	Oven is too hot.	Reduced temperature or recheck oven setting.
Bread loaf bakes over pan, poorly shaped.	Oven temperature too low.	Recheck oven temperature
Cakes not baked in center.	Oven too hot.	Set oven temperature 25 degrees lower, and bake recommended time.
	Type and size of pan.	Use suggested pan size, glass baking dishes usually bake at a lower temperature.
Cakes fell.	Underbaked, oven door opened too often.	Keep oven door closed. Bake recommended time.
Cakes not level.	Range or oven shelf not level	Place a marked glass measuring cup, filled to one marking with water, in center of oven rack. If water level is uneven, refer to installation instructions for leveling range.
	Pan too close to oven wall.	Allow minimum of 1-1/2 inches clearance on all sides.
Foods undercooked after recommended cooking time has elapsed.	Oven not up to temperature.	Set oven temperature 25 degrees higher and bake recommended time.
	Improper use of foil.	Foil should not be placed on floor of oven, over a cooking shelf or thermostat bulb.

# USING THE BROILER

The broiler uses infra-red rays that travel in straight lines. These rays will sear the outside of the food while locking in all the flavor and juices. The cooking area of the broiler will get smaller as the food is moved closer to the element. In high rack positions, the rays will not reach the corners of the broiler grid. If you have never used an Infra-Red broiler follow this rule of thumb:

Outside Charred and Inside Rare ..... High Rack position and short time  
Outside Charred and inside Well Done ..... Lower Rack position and less time

## SPECIFICS

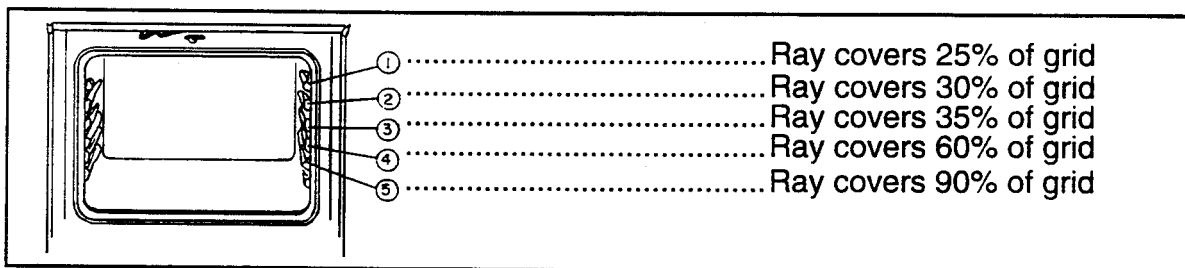

## BROILING TIPS

1. The best foods to broil include steaks, hamburgers, chicken, fish, pork or lamb chops and vegetables.
  2. Remove excess fat from the meat and slash the edges to prevent them from curling.
  3. Do not pierce meats before or after broiling. If the meat has been pierced it may lose some juices.
  4. Season the meat after it has browned. Uncooked meat that is seasoned may become tough.
  5. Broiled food, EXCEPT FOR FISH, should be turned at least once.
  6. Fish should be broiled with the skin side down.
  7. Broil hamburgers on shelf position 4.
- NOTE: The broiler does not need to be preheated before using.**

## **⚠ WARNING**

**Do not line the broiler pan with foil. Foil will not allow grease and liquids to drain from the food causing smoking or fire.**

## BROILER PAN POSITION

Position broiler pan with short sides parallel to the back of the oven so that it is directly lined up under the broiler.

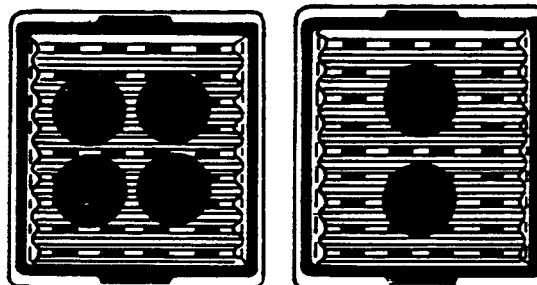

# BROILING

## TO USE THE BROILER

### TO BROIL:

1. Set the selector to BROIL.
2. Turn the Thermostat Knob to BROIL.
3. You may broil with the oven door open or closed.

### WHEN FINISHED:

1. Turn all controls to OFF.

**Note: Do not use the door lock lever while you are baking or broiling. Moving the lever to the right may cause the door to lock at normal temperatures. If you accidentally lock the door, turn off the oven and wait for it to cool before you attempt to move the lock lever and re-open the door. DO NOT FORCE THE LEVER OPEN.**

### **⚠ CAUTION**

To avoid the risk of fire, personal injury or property damage, use the broiler grid only in the proper position. If it is put in upside down, grease will collect in the rim and could be hazardous.

### **⚠ CAUTION**

Do not use Teflon II® coated griddle or fry pan with nonremovable handle for broiling.

Do not cover broiler grid with foil. It prevents fat from draining and can cause fire or smoke.

## BROILING CHART

FOOD	TOTAL BROILING TIME (MIN.)
<b>BEEF</b>	
Steaks (1" thick)	
Rare .....	10
Medium Rare .....	11
Medium .....	12-14
Well Done .....	20
Steaks (1-1/2" thick)	
Rare .....	15
Medium .....	20-25
Well Done .....	30
Ground Beef Patties (3/4" to 1" thick) .....	8-15
<b>CHICKEN</b>	
Breast (split with ribs) .....	20-25
Breast (boneless) .....	13-17
<b>BREADS</b>	
Broil Until Toasted	
<b>FISH</b>	
Filets or Steaks .....	10
<b>PORK (cured)</b>	
Bacon .....	2-6
Ham Slice (cook before eating)	
1/2" thick .....	19-20
1" thick .....	20-30
Ham Slice (fully cooked)	
1/2" thick .....	19-20
1" thick .....	20-30

# SELF CLEANING THE OVEN

## STEPS TO FOLLOW BEFORE SELF CLEANING

1. Remove all containers, spoon holders, spices and etc., from the range top.
2. Remove all pots, pans and oven racks from inside the oven. These things will become too hot during the cleaning cycle causing them to warp.
3. Wipe up the excess spills from the oven interior.
4. Remove soil from the oven frame, side of door and door liner.

## TIPS ON SELF CLEANING

- The best time to clean your oven is in the evening, when you are finished using it for the day.
- A small amount of smoke is normal, excessive smoke may indicate that there is a faulty gasket or too much food has been left in the bottom of the oven.
- The oven should always be cleaned before it gets too dirty. If you cannot clean your oven in one cycle, repeat the cleaning cycle.
- Never use a chemical oven cleaner. Some chemicals may have a reaction in the oven interior at high temperatures.
- DO NOT use the cleaning cycle if the oven light cover is not properly in place.

### **⚠ WARNING**

Do not clean the oven door gasket. The gasket can be damaged as a result of rubbing or moving.

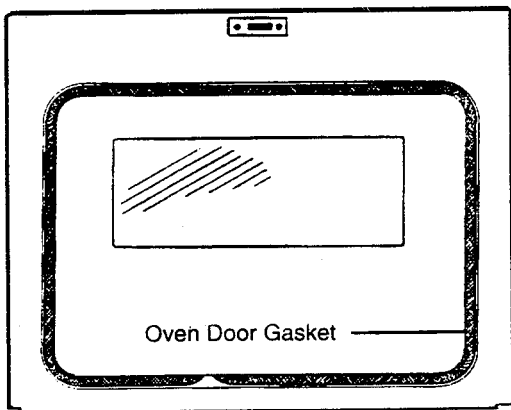

### **⚠ WARNING**

To reduce the risk of severe burns, do not obstruct or touch areas near the vents or range surface. These areas become hot during the cleaning cycle.

## SUGGESTED SELF CLEANING TIMES

LIGHT TO MODERATE SOIL .....	2 HOURS
HEAVY SOIL .....	3-4 HOURS

# SELF CLEANING THE OVEN

## SETTING THE SELF CLEANING CYCLE

1. Turn the oven selector knob to "CLEAN".
2. Turn the Temperature knob completely around to the stop position.
3. Make sure the clock is set at the correct time of day.
4. Set the start time using the Start Time Knob.
5. Set the stop time using the Stop Time Knob.
6. Make sure the oven door is closed.
7. Lock the oven door by moving the Door Lock Lever into the locked position as shown below.
8. When the oven has cooled, the locking mechanism releases and the door can be unlocked and opened.

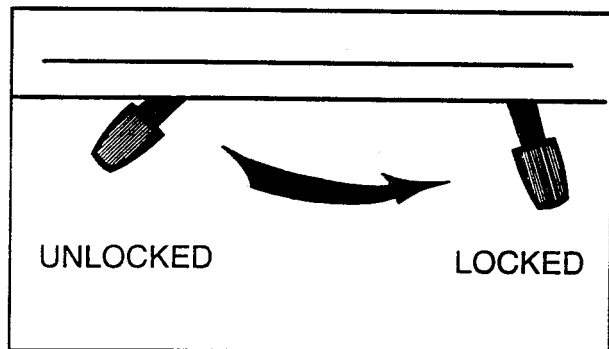

## IMPORTANT

**Do not try to force the oven door open. This can damage the automatic door locking system.**

**Note: You must set a stop time to operate the cleaning cycle.**

## TO INTERRUPT THE SELF CLEANING CYCLE

1. Turn the Stop Time knob to match the time of day.
2. The shaft will pop out and the oven operating light will go out.
3. Turn the Temperature knob and the selector knob to "OFF".
4. Allow the oven to cool before you attempt to open the door.

## WARNING

**To reduce the risk of fire, do not store or place combustible materials, gasoline or other flammable liquids near your range.**

## WHAT TO EXPECT DURING SELF CLEANING:

- The oven and the clean indicator lights will be on until the cleaning cycle is finished.
- The first few times the self cleaning cycle is used, there may be some minor smoking and slight odor as the oven insulation "cures." This will disappear after the first few cleaning cycles.
- Vapor and warm air will pass through the oven vent. Do Not Obstruct the Air Flow.
- The vapor and smoke generated during the self cleaning cycle is cleaned before it is discharged into the room.
- The outer surfaces of the range will become hot. Do Not Touch The Outer Areas Of The Range During Self Cleaning.

# CLEANING THE RANGE

PART	MATERIALS TO USE	GENERAL DIRECTIONS
Bake Element		Do not clean the bake element or broil element. Any soil will burn off when the element is heated. The bake element is hinged and can be lifted to clean the oven bottom.
Broiler Pan and Grid	Soap and a Nonabrasive Plastic Scouring Pad	Drain fat, cool pan and grid slightly. (Do not let soiled pan and grid stand in oven to cool.) Sprinkle with soap. Fill the pan with warm water. Let pan and grid stand for a few minutes. Wash: scour if necessary. Rinse and dry. Option: The broiler pan and grid may also be cleaned in a dishwasher.
Oven Control Knobs	Mild Soap and Water	Pull off knobs. Wash gently but do not soak. Dry and return controls to oven, making sure to match flat area on the knob to the flat area on the shaft.
Outside Finish and Backguard	Soap and Water	Wash all glass with cloth dampened in soapy water. Rinse and polish with a dry cloth. If knobs are removed, do not allow water to run down inside the surface of glass while cleaning.
Inside Oven Door	Soap and Water	Clean the outside of the door and the window area with warm soapy water. DO NOT clean the oven door gasket. The gasket should not be moved while cleaning. Avoid getting any cleaning materials on the gasket.
Oven Interior Surfaces	Soap and Water	Cool before cleaning. Frequent wiping with mild soap and water will prolong the time between major cleanings. Be sure to rinse thoroughly.
Oven Racks and Storage Drawer	Soap and Water	For heavy soil, clean by hand and rinse thoroughly. Remove the drawer and racks for ease in cleaning. Be sure the drawer is dry before replacing it.

To prevent the possibility of stains wipe up all spills immediately with a dry cloth. Acids will stain even the most stain resistant materials and finishes, so take extra care when you are cooking with vinegar, milk, lemon juice and sauces and tomatoes.

**Hard To Clean Oven Racks:** Sprinkle baking soda and vinegar on the racks and use a nonabrasive scrub pad to remove the soil. If the soil is not removed place the racks in a garbage bag with a cup of ammonia. Close the bag tightly and leave the racks for 24 hours. When you are ready to open the bag make sure you have turned it away from your face because the odor will be strong. Rinse the racks with clean water.

# CARE AND MAINTENANCE

## REMOVABLE OVEN DOOR

The oven door is removable for convenience when cleaning large spills or the back of the oven. Do not immerse the oven door in water. **DO NOT PLACE HANDS NEAR THE DOOR HINGES WHEN THE DOOR IS NOT IN PLACE.**

### TO REMOVE OVEN DOOR:

1. Open the door to the first stop position (approximately 5 inches).
2. Grasp the door firmly at each side and lift it upward and off the hinges.

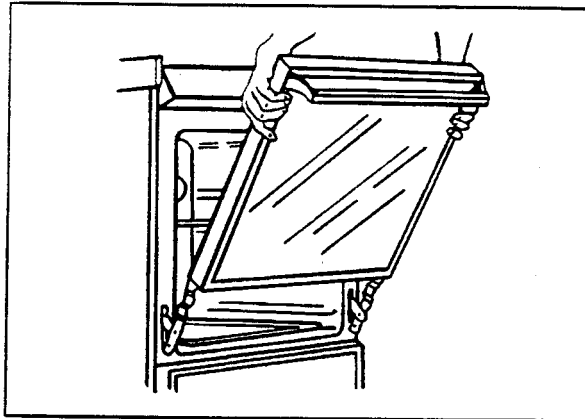

**CAUTION**  
OVEN DOOR IS HEAVY.

### TO REPLACE THE OVEN DOOR:

1. Align the door with the hinge arms.
2. Slide the door down and into place. Be sure the door is all the way down on the hinges before closing, to prevent the possibility of chipping porcelain or scratching chrome.

## STORAGE DRAWER

The storage drawer is for storing pots and pans. The drawer can be removed to make it easier to clean under the range.

### TO REMOVE THE STORAGE DRAWER:

1. Pull the drawer straight out to the first stop. Lift the front and pull out to the second stop.
2. Let the front of the door rest on the floor. Place your hands toward the back of the drawer and lift it out.

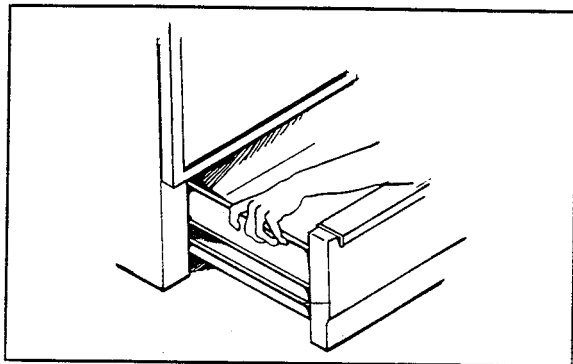

FIGURE 1

### TO REPLACE THE STORAGE DRAWER:

1. Place the set of rollers on the drawer behind the set of rollers on the oven. (As shown in figure 2)
2. Align the guides and push the drawer back into position.

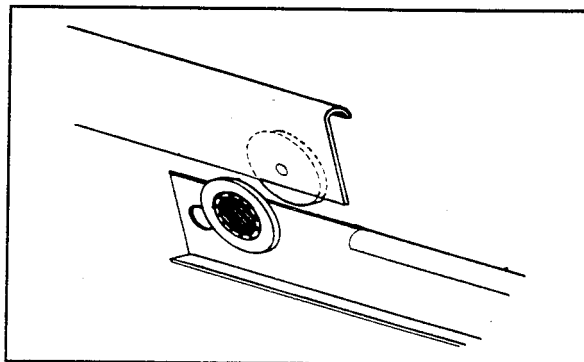

FIGURE 2

## REPLACING THE OVEN LIGHT

### **WARNING**

Make sure the oven, light cover, and bulb are cool before you begin. Be sure the oven power is off. You can turn it off at the main fuse or circuit breaker.

### STEPS TO CHANGE THE LIGHT:

1. Disconnect the oven power at the main circuit breaker.
2. Unscrew the glass cover counterclockwise.
3. Unscrew the light bulb counterclockwise.
4. Replace the bulb with a 40-watt appliance bulb.
5. Replace the bulb cover.
6. Reconnect the power to the oven.

### **WARNING**

You must replace the cover after changing the bulb. The cover protects the bulb from becoming too hot. Be careful not to drop the bulb or cover. They are made of glass and can cause severe injuries if broken.

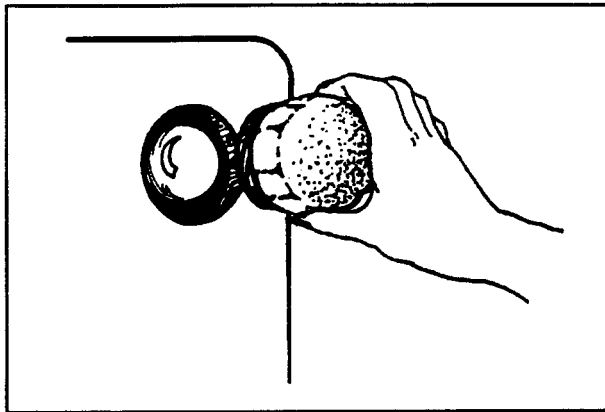

**NOTE: Do Not Over Tighten The Bulb Cover. Replace the cover so it is secure but not tight. After repeated use of the oven, a cover that has been over tightened will be very difficult to remove.**

## HOOD EXHAUST SYSTEMS SAFE OPERATION

### **CAUTION**

Clean ventilating hoods frequently. Grease should not be allowed to accumulate on hood or filter.

### **CAUTION**

When flaming foods under the hood, turn the fan off. The fan, if operating, may spread the flame.

# COMMONLY ASKED QUESTIONS

**Question:** I've put an oven thermometer in my oven and noticed it does not maintain a constant temperature. Do I have a problem?

**Answer:** To maintain a temperature for baking, your oven will cycle off and on. You may see a "swing" in temperature of as much as  $\pm 25^{\circ}\text{F}$ . This temperature cycling is considered a normal procedure in range operation.

**Question:** Is it normal for my rangetop to get warm during use?

**Answer:** The porcelain rangetop may become warm to the touch while the range is being used to bake, broil or self clean. The longer the range is operated, the more the heat can be conducted to the rangetop.

**Question:** If my range clock is not working can I still self clean my oven?

**Answer:** No. Your oven control uses the oven clock to help start and stop your self-clean cycle.

**If the oven does not heat:** Check to be sure the oven has been set to the correct temperature and/or that the oven is not set for a delayed bake function.

**If the clean cycle does not start:** Check to see that the oven timer is not set for a delayed start.

**Question:** Can I use the Timer during oven Cooking?

**Answer:** The timer can be used during any cooking function and is especially handy when baking or broiling. The Timer can also be used while you are using the automatically timed functions.

**Question:** Should there be any odor during the cleaning cycle?

**Answer:** Yes. There may be a slight odor during the first few cleaning cycles. Failure to wipe out excessive soil may also cause an odor when cleaning.

**Question:** What should I do if excessive smoking occurs during cleaning?

**Answer:** This is caused by excessive soil, shut the oven off. Open windows to rid room of smoke. When the oven has cooled and the door unlocks, wipe up the excess soil and reset the cycle.

**If the latch lever cannot be moved to an unlocked position:** The oven must be cool to move latch lever to the left or to an unlocked position. If the latch does not unlock after the oven has cooled call your dealer or an authorized service agency.

**DO NOT FORCE THE LATCH LEVER. IF THE LEVER IS FORCED OPEN THE COSTLY SELF CLEAN MECHANISM WILL BE DAMAGED.**

# ADJUSTING THE OVEN TEMPERATURE

## HOW TO ADJUST OVEN TEMPERATURE

The oven has been calibrated at the point of manufacture. However, if you wish to adjust the oven temperature to make it bake hotter or cooler, follow these steps.

### To Adjust The Temperature:

1. Remove the oven Thermostat Knob.
2. Loosen the metal plate on the back of the knob using a philpshead screw-driver.
3. Turn the knob handle so the pointer is set at the desired number of degrees higher or lower. Each line represents 10°F.
4. Tighten the screws and replace the knob.

**Note you should only move the pointer plate 10° each time.**

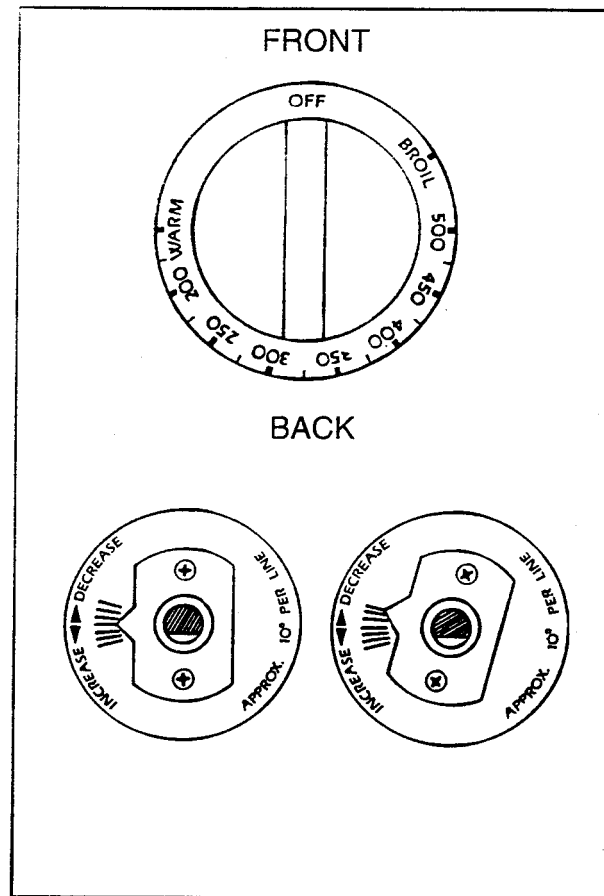

**Rest assured against unexpected repair bills!**

**Amana™  
Asure™**

### EXTENDED SERVICE PLAN

Amana is pleased to offer an important opportunity for long-term service protection on your new Amana appliance. The Asure Extended Service Plan is specially designed to supplement the strong warranty that already accompanies your appliance, and it combines with this standard warranty to provide budget-protection coverage on your appliance for up to five full years, covering parts, labor and travel charges. Please contact us at:

**Amana Consumer Affairs Department  
Amana, Iowa 52204  
1-800-843-0304**

## **BEFORE YOU CALL A SERVICE PERSON**

Make sure you have followed the instructions in your Use and Care Manual. Avoid unnecessary service calls for difficulties that are not a result of defective workmanship or materials. If the problem is not caused by workmanship or materials, or if the component is customer replaceable, you will be charged for a service person's travel expenses and labor, even though the product may be under warranty. The following items are considered customer replaceable: oven racks, light bulbs, control knobs which can be removed by pulling them off the control shaft. The heating elements in the rangetop can be replaced individually by an authorized servicer.

## **WHEN SERVICE IS REQUIRED**

The dealer from whom you purchased the range can give you the name of your nearest Authorized Service Center. Help them give you prompt service by giving them:

1. An accurate description of the trouble.
2. Complete model, serial, and manufacturing numbers located on the oven frame below the oven door. Can be seen by slightly pulling out the storage drawer.
3. Proof of purchase (sales receipt on request)

Repair by an unauthorized servicer that results in subsequent failure will void the warranty. Warranty details are contained in the warranty certificate enclosed with this booklet. Keep an accurate record of any service calls: what was done, who serviced the range, and the date of service.

We have a vast network of Authorized Service Centers in the U.S., however, if you should have a service problem that is not resolved please write:

**Consumer Affairs Department  
Amana Refrigeration, Inc.  
Amana, Iowa 52204**

For quicker service or for answers to questions concerning product usage, installation, and warranty, call:

**CONSUMER INFORMATION LINE  
TOLL FREE 1-800-843-0304**